

## Used Paints

- A – Body color
- B – Semi gloss black
- C – Aluminium
- D – Steel
- E – Flat Black
- G – Chrome silver
- H – Interior color
- I – Semi gloss brown
- K – Moon white
- L – Clear red
- M – Red

## PE Parts

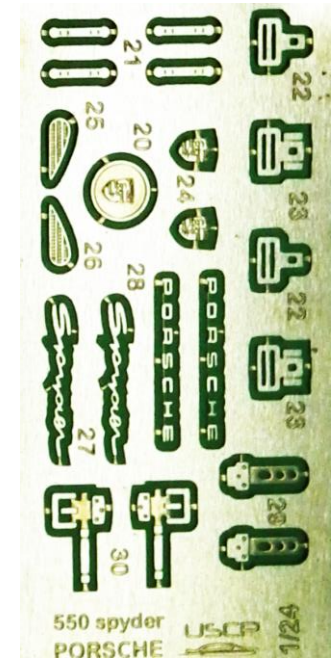
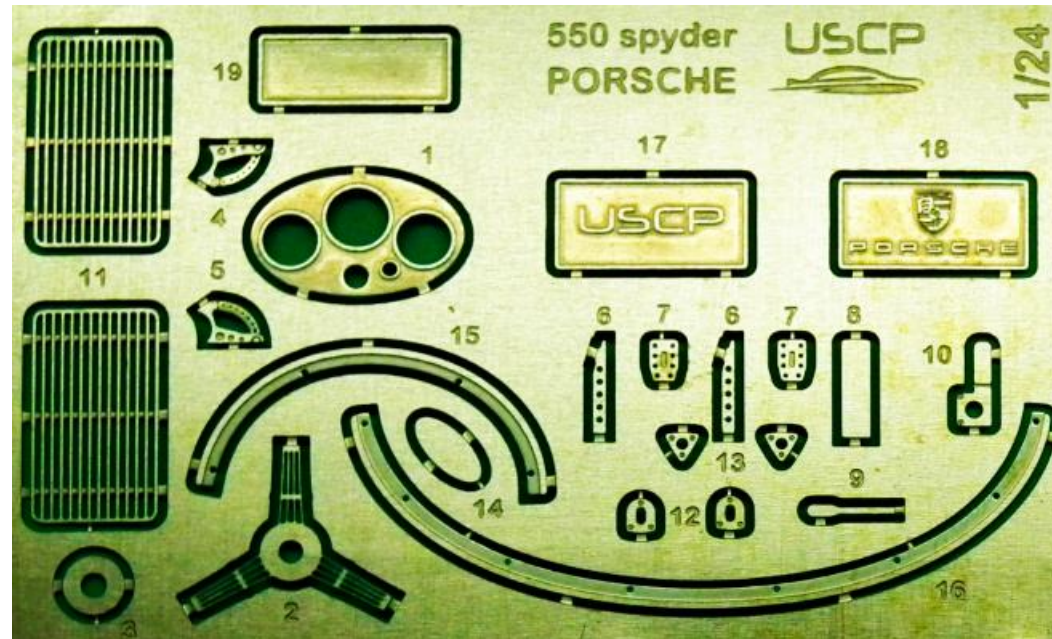

## Spyder Versions

Our kit reproduces late version of 550 – 1955-56, chassis numbers from 550-0044 and till the end of production

Most of original cars were painted in German Racing Silver. But also some cars were White, French Blue, Red and Yellow.

Interior was Beige, Red, Black, Blue or Brown.

For extra reference you can use - <http://type550.com>

## Clear Parts

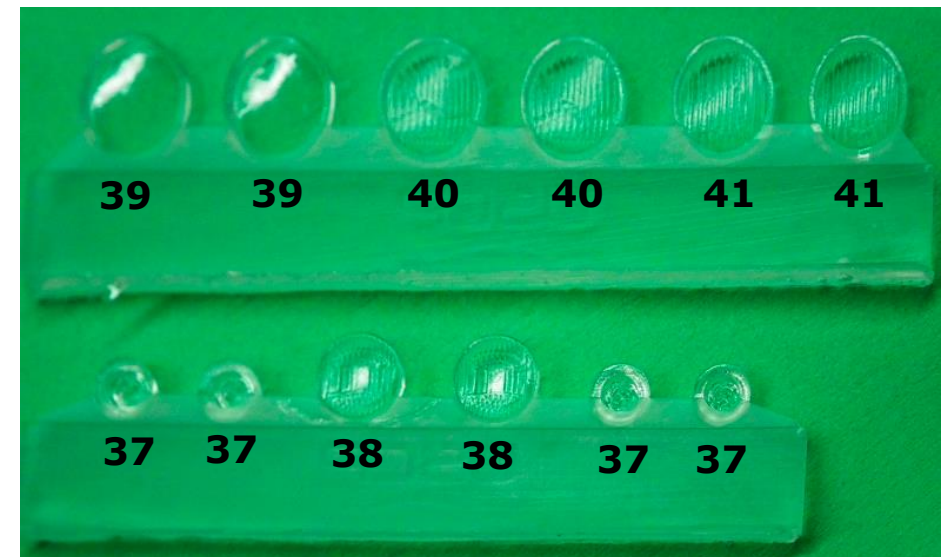

# Resin parts

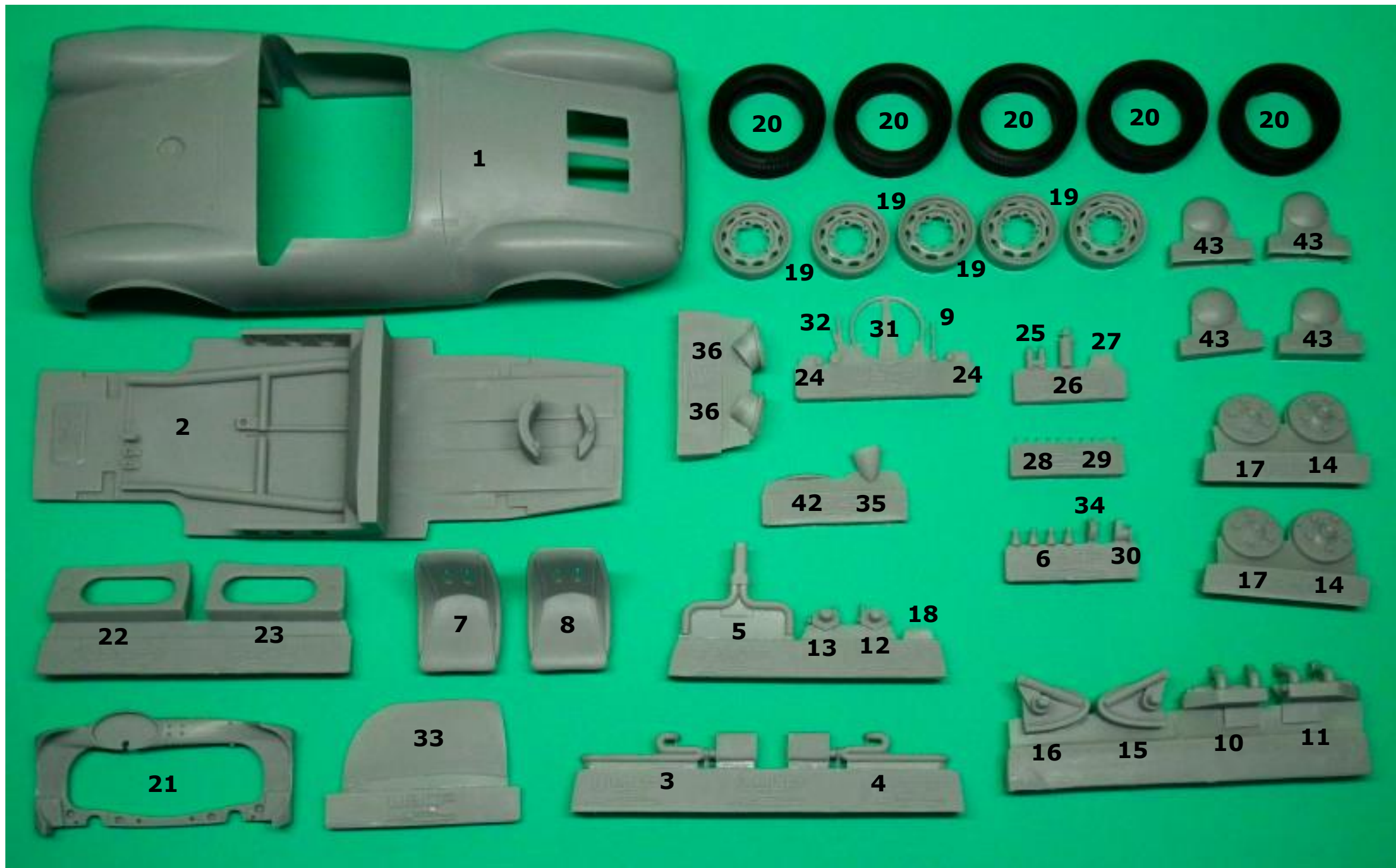



# 1. Chassis and exhaust

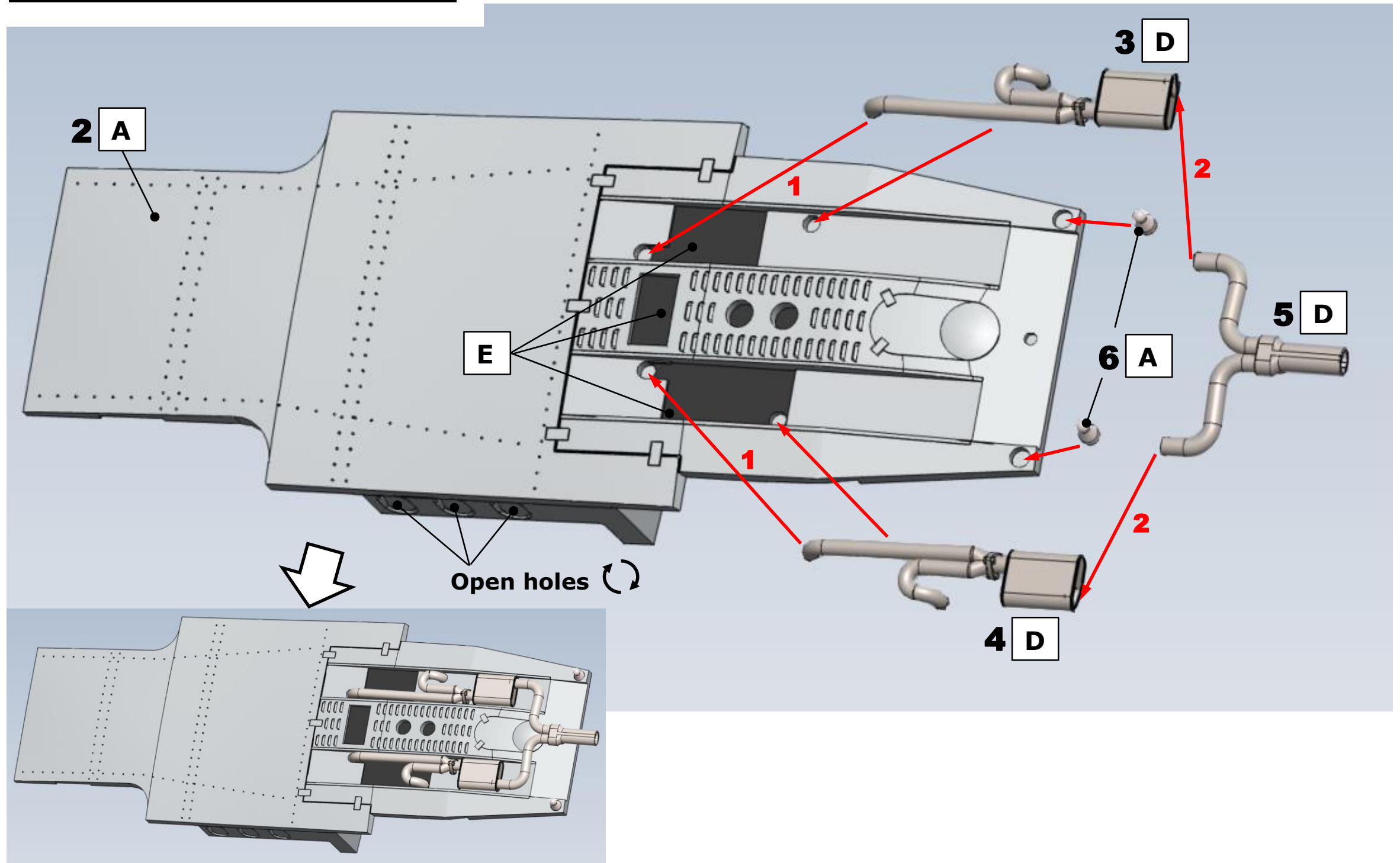

## 2. Front suspension and pedals

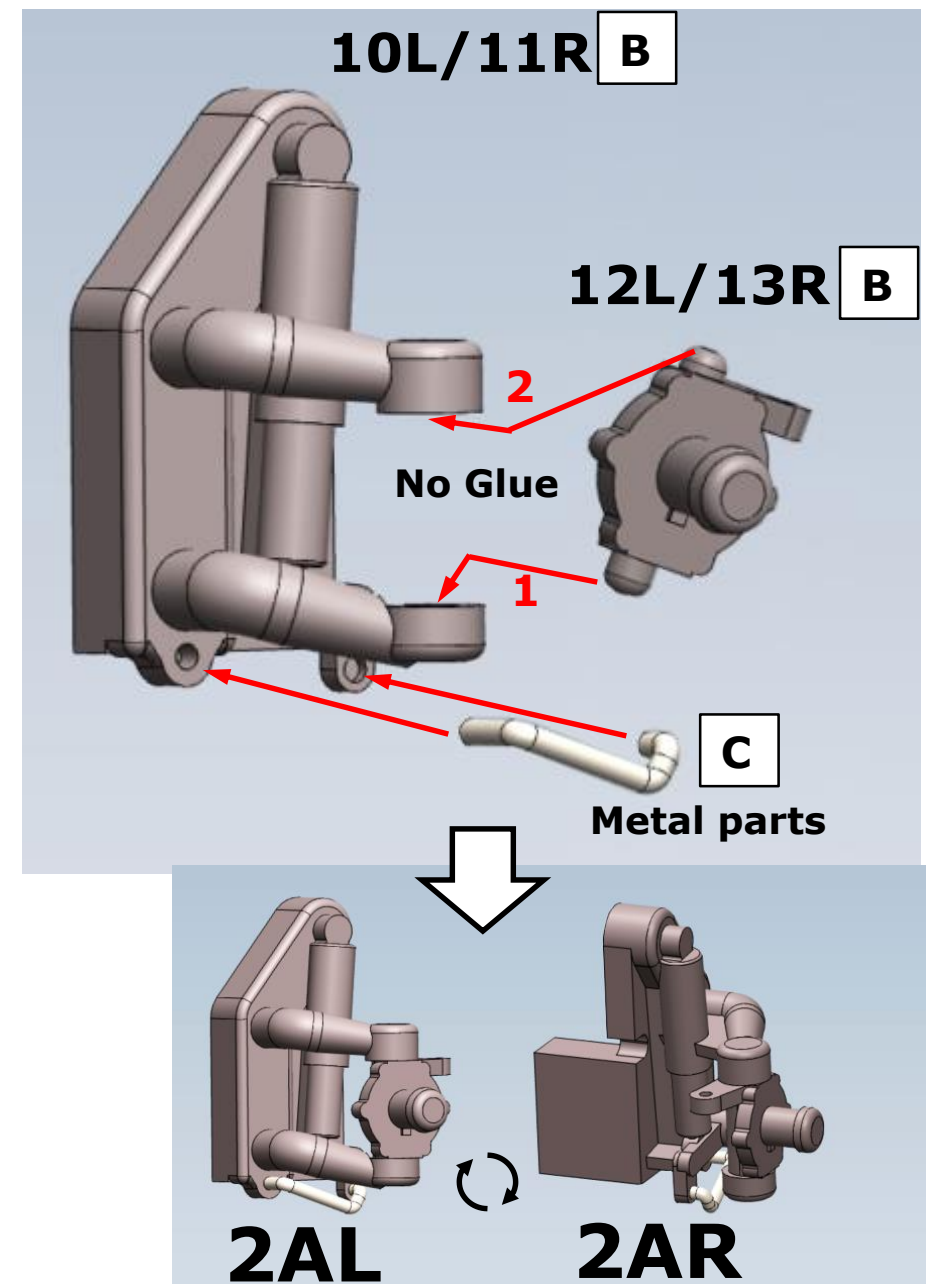
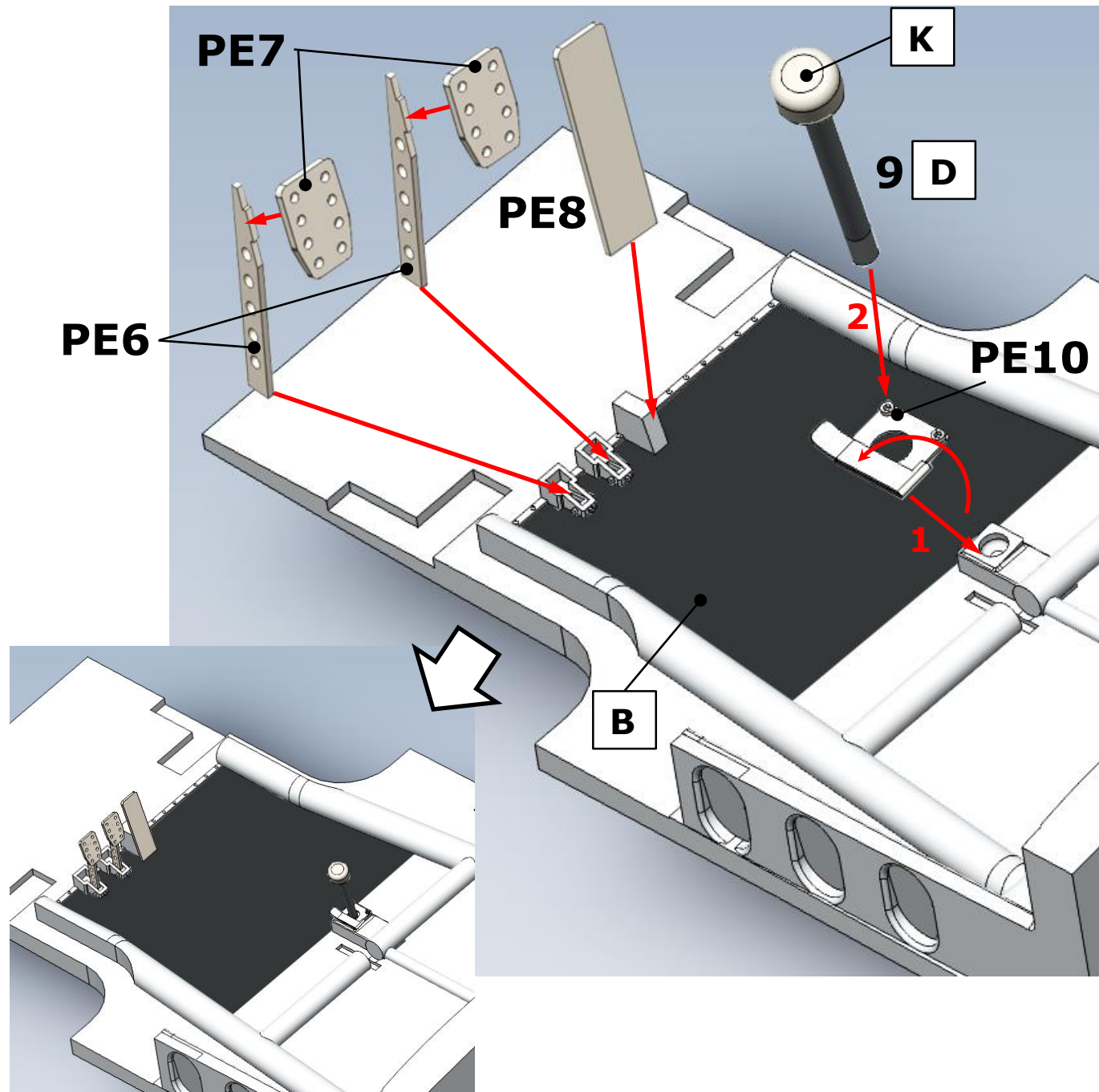

### 3. Front and rear suspension installation

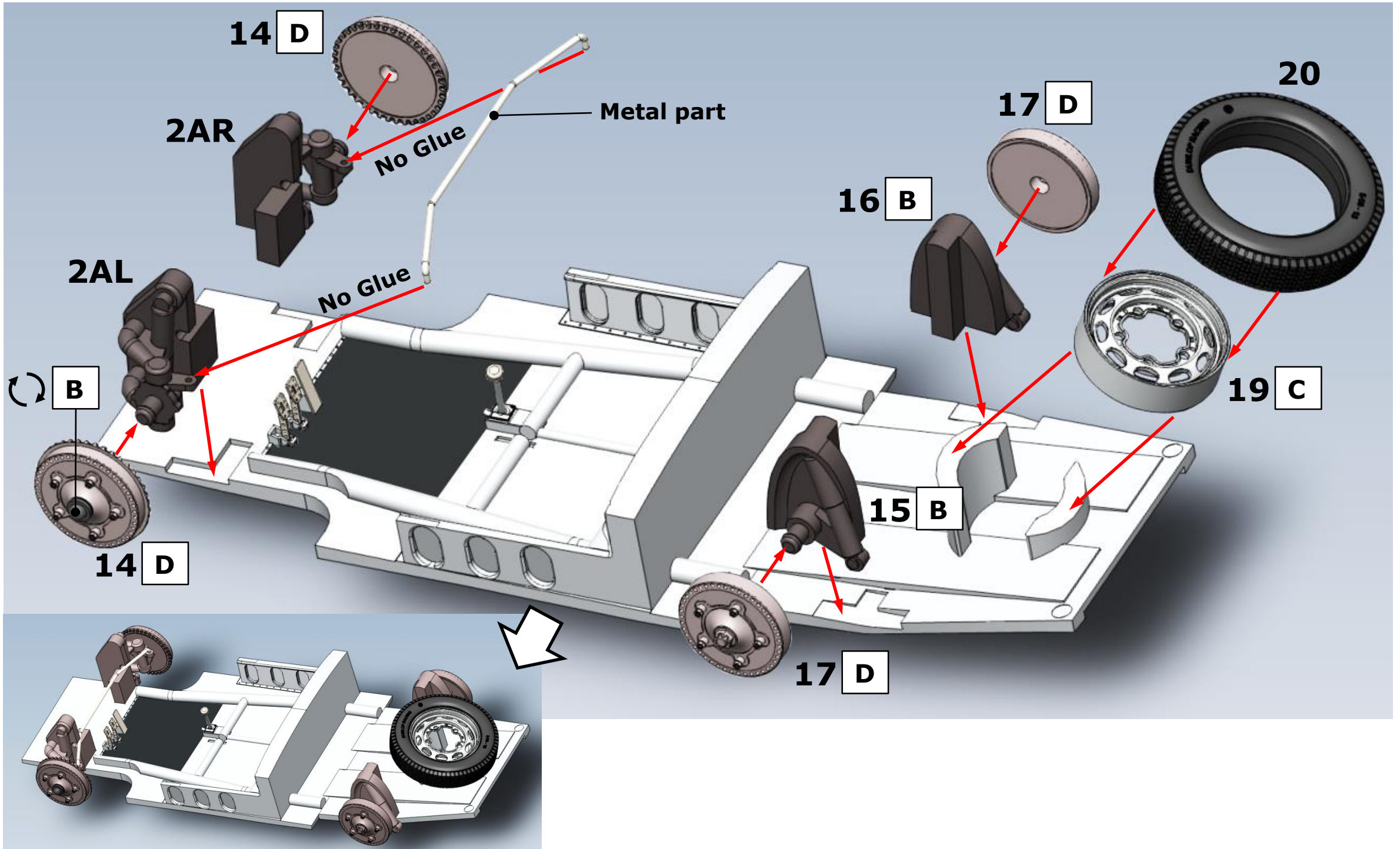



## 4. Body assembling

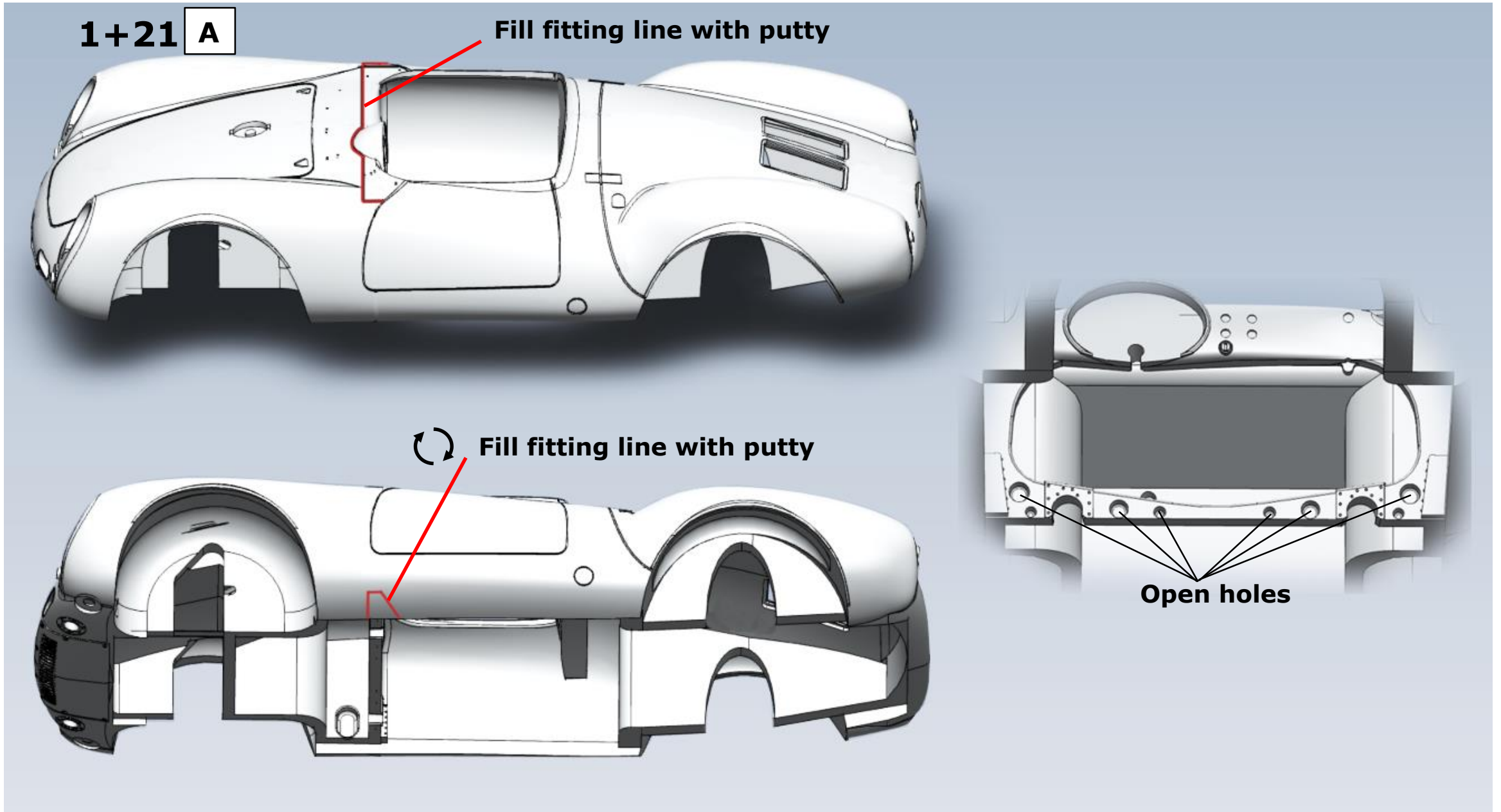

## 5. Door panels

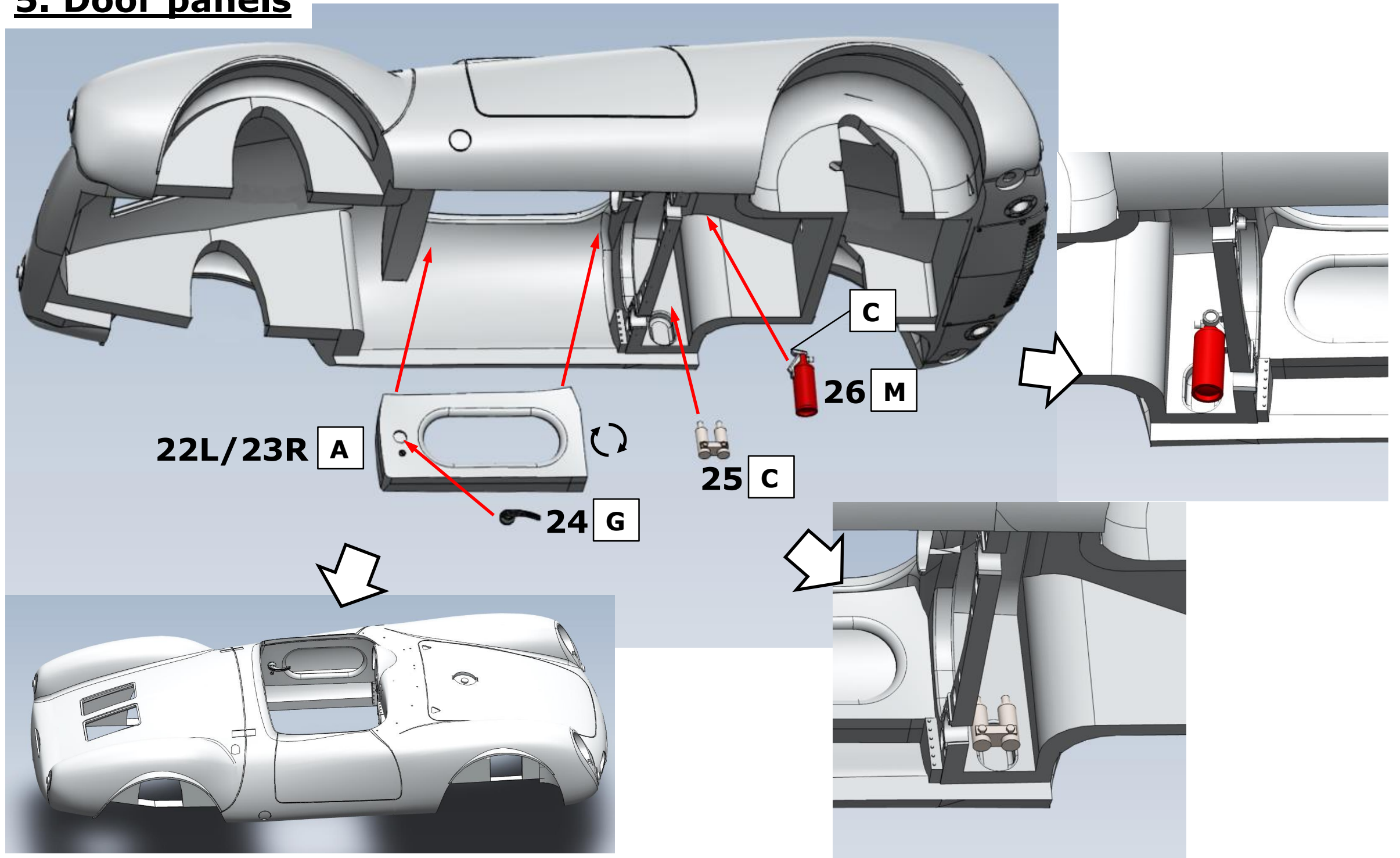

## 6. Dashboard

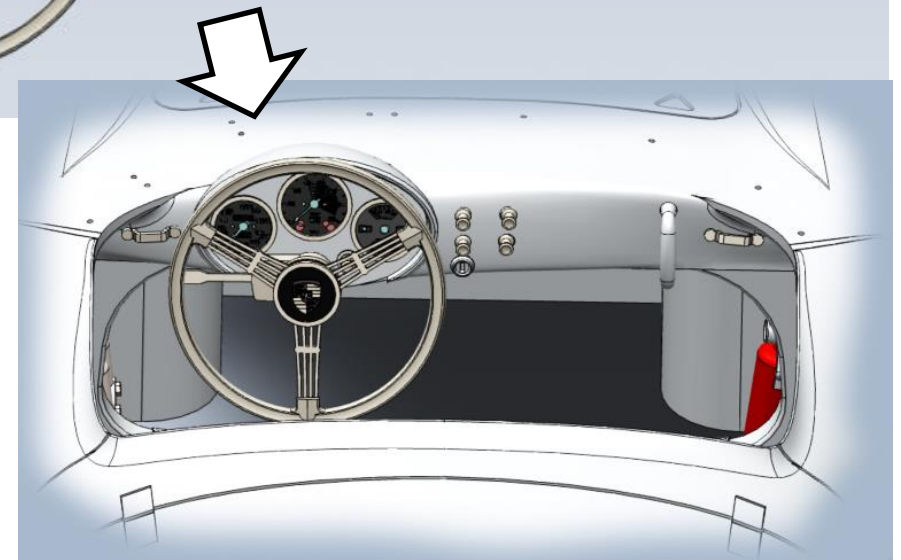
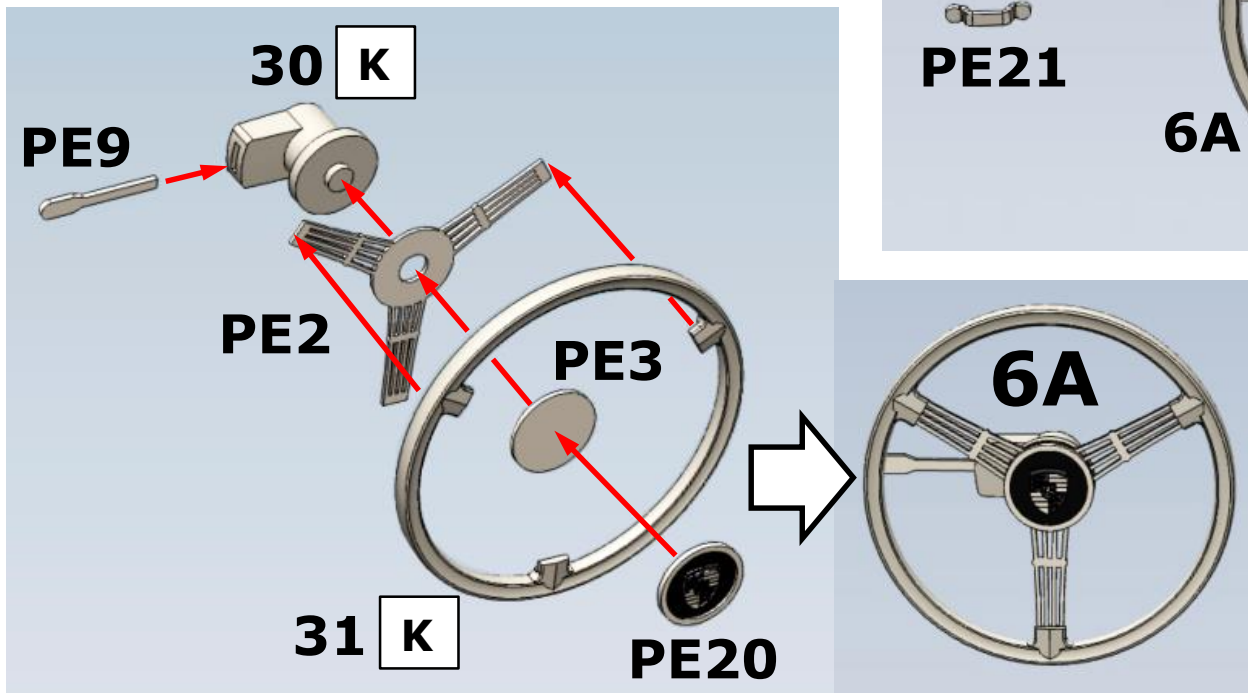
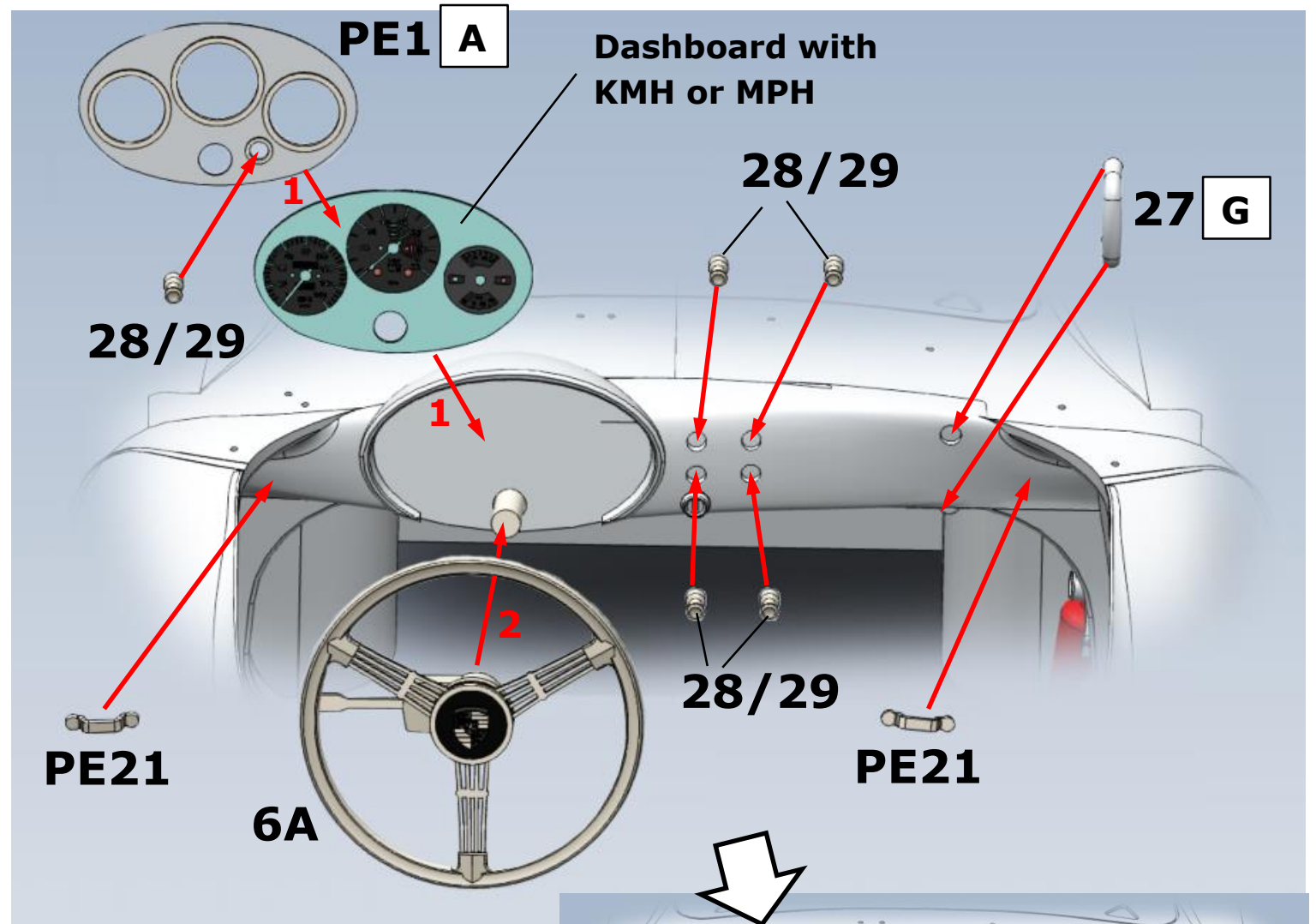
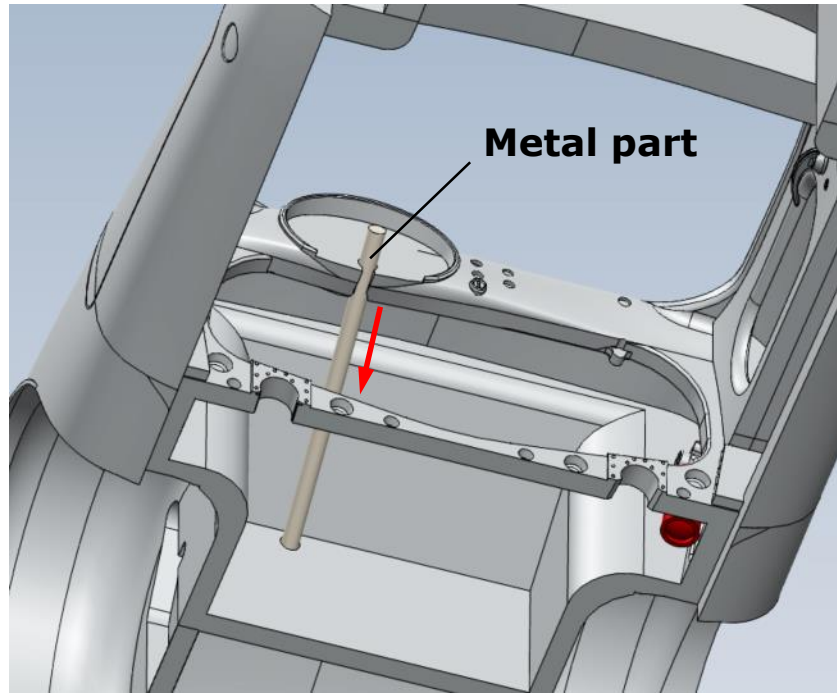



## 7. Assembling chassis with body

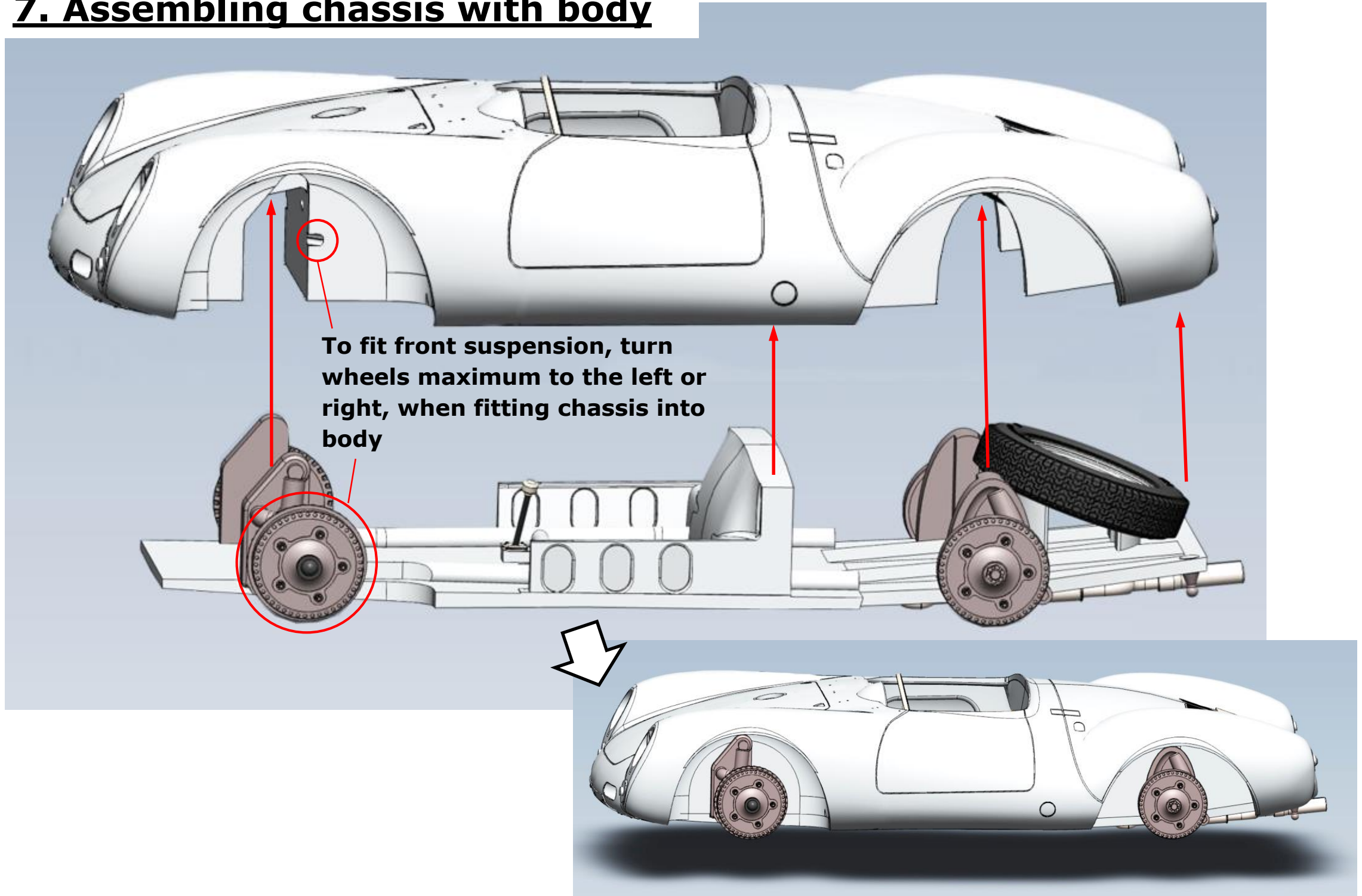

# 8. Interior

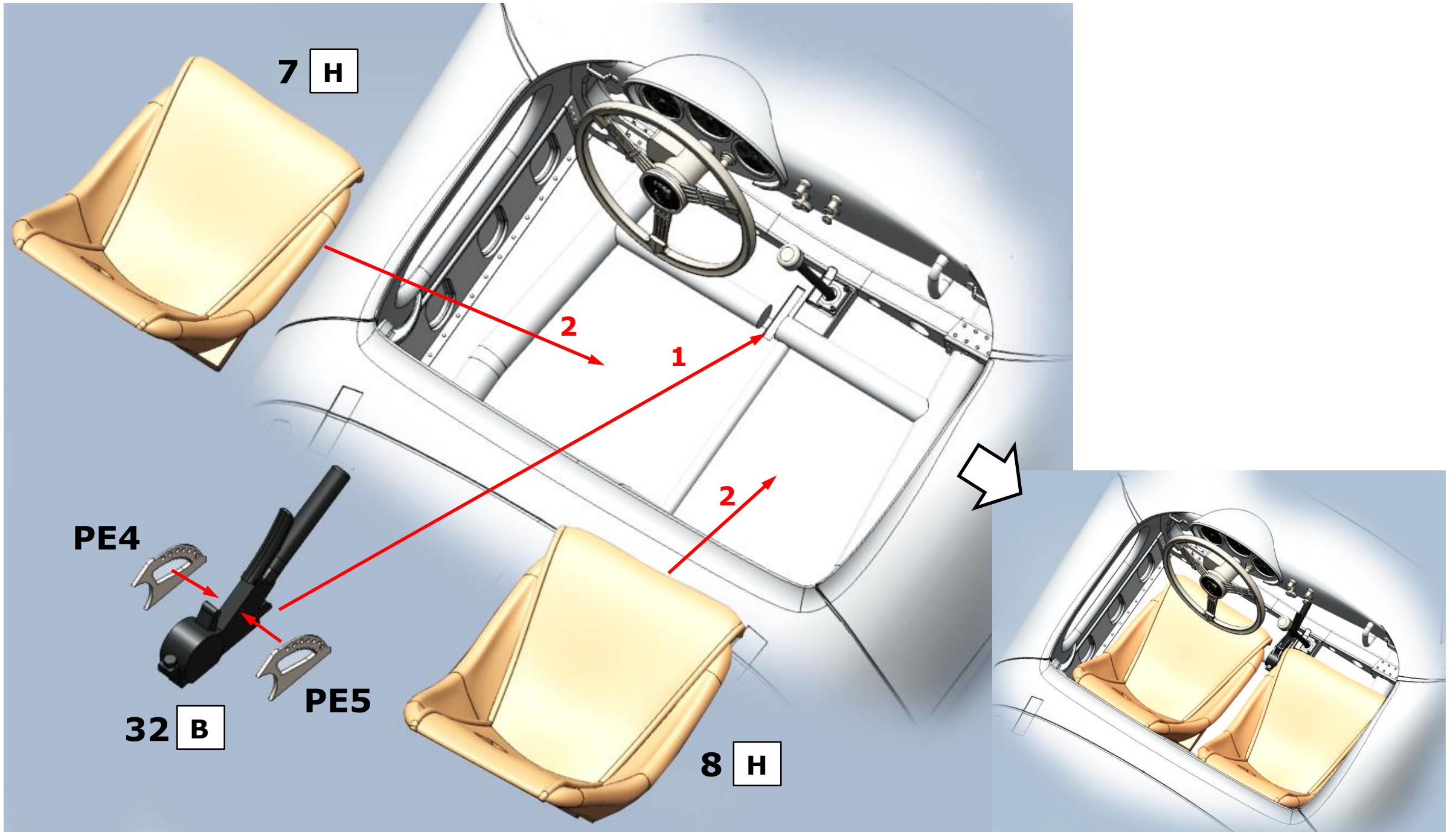



# 9. PE parts

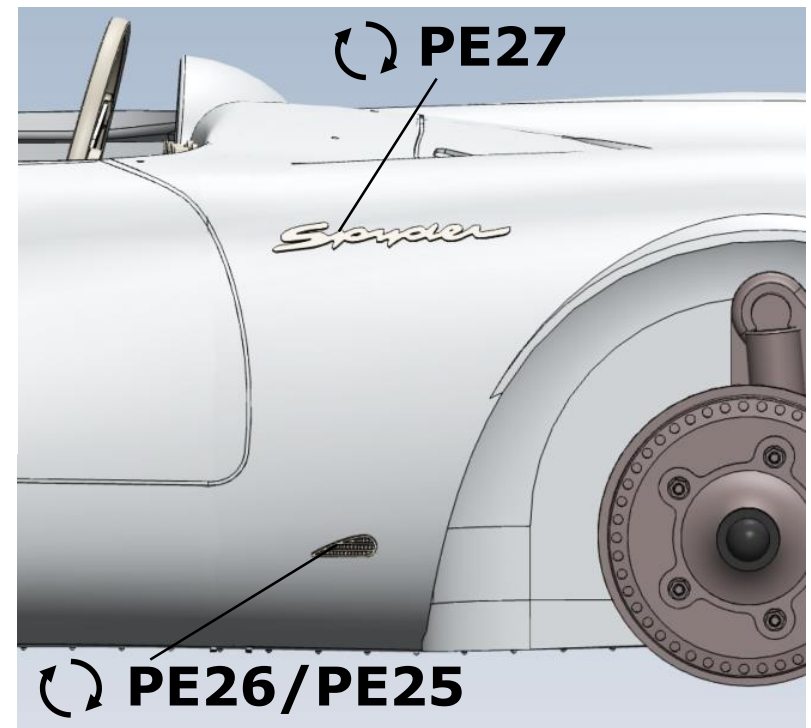
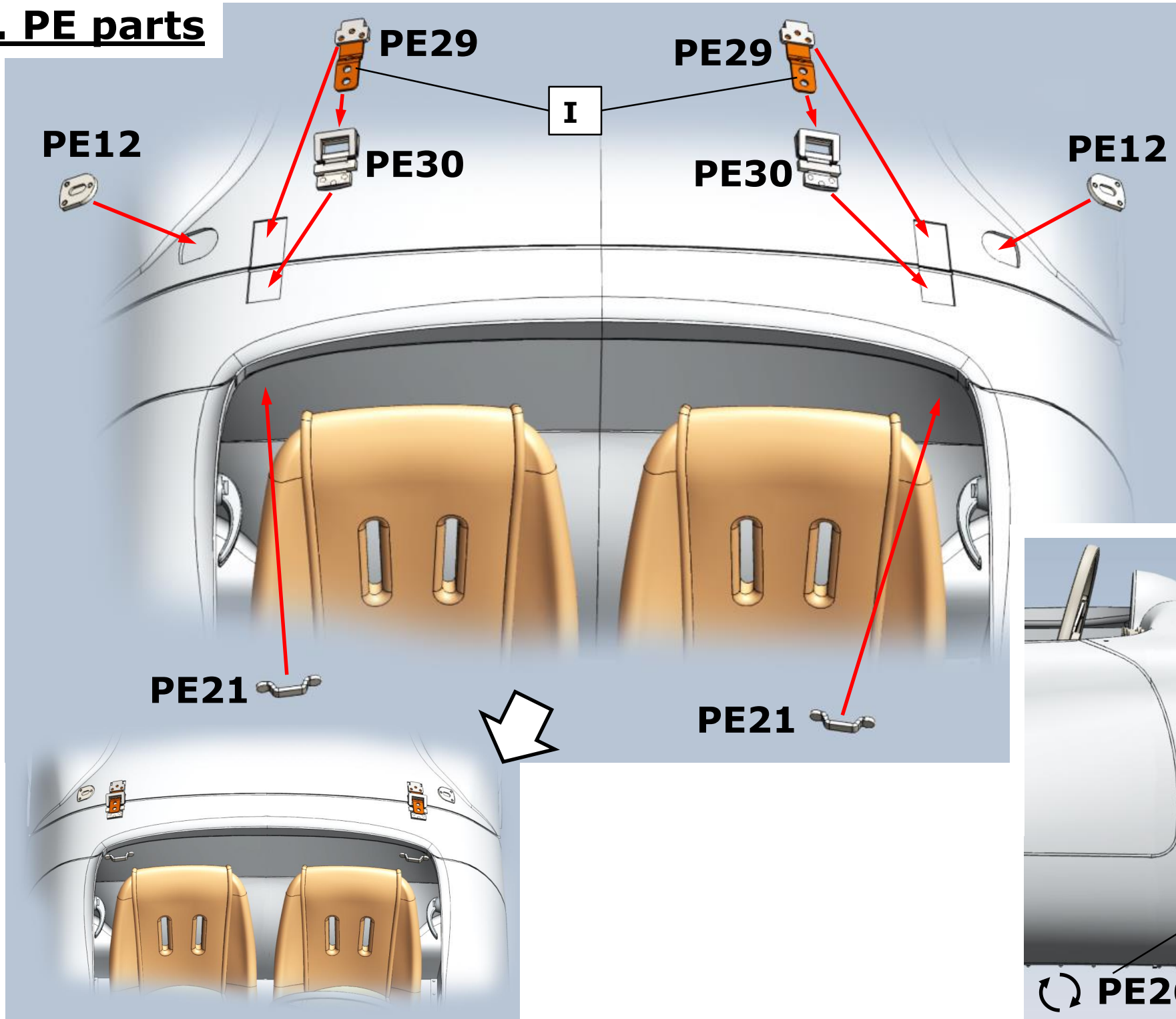

# 10. Top of body

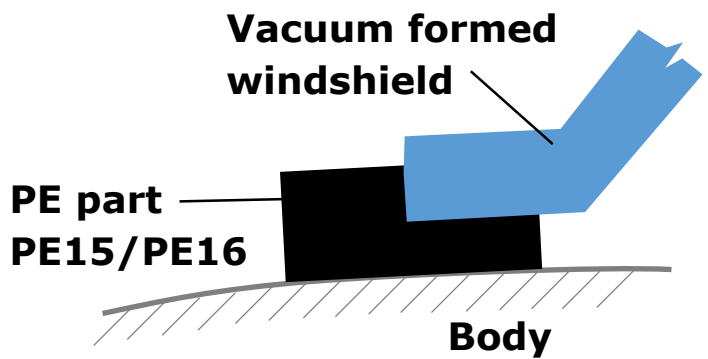
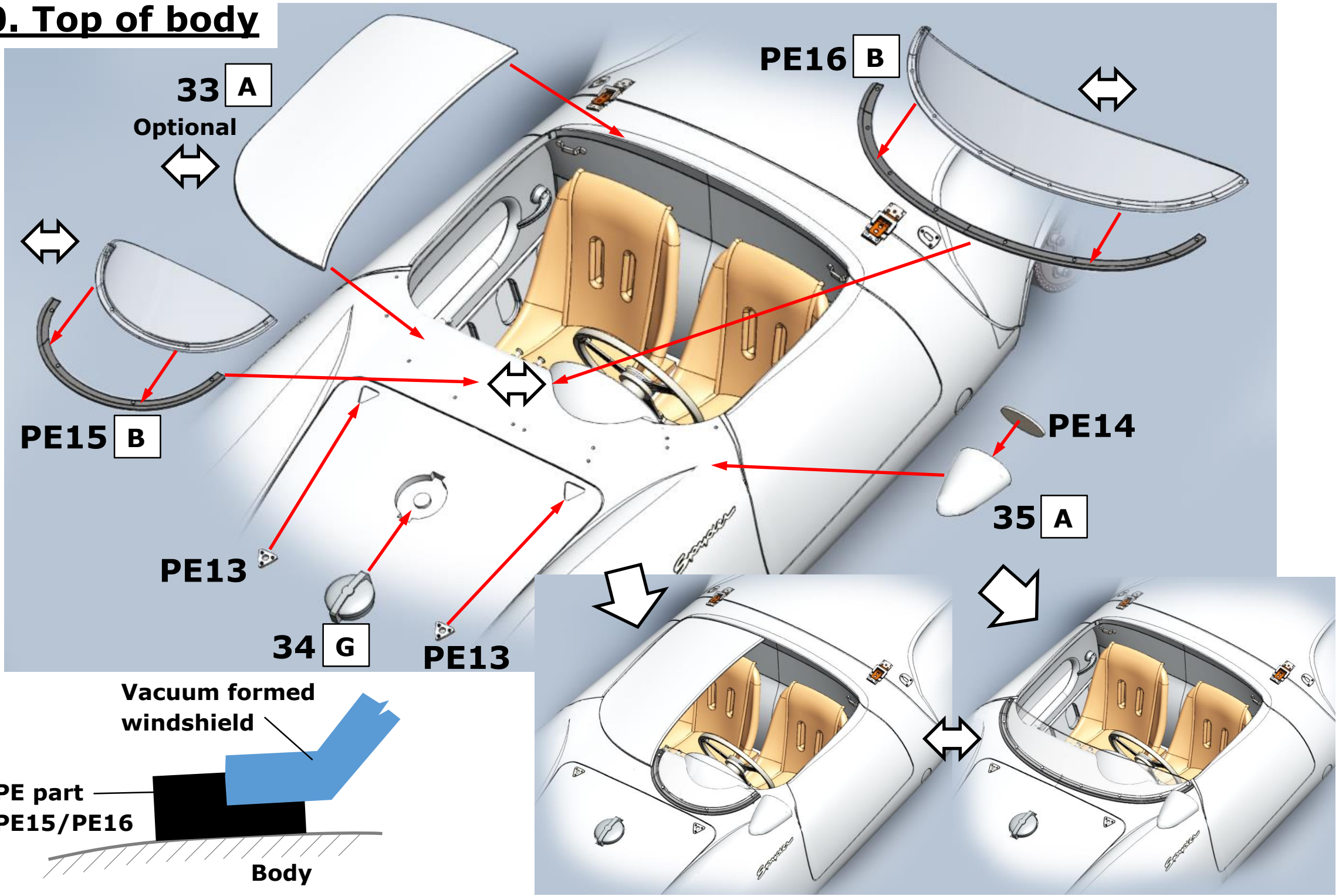



# 11. Front part assembly

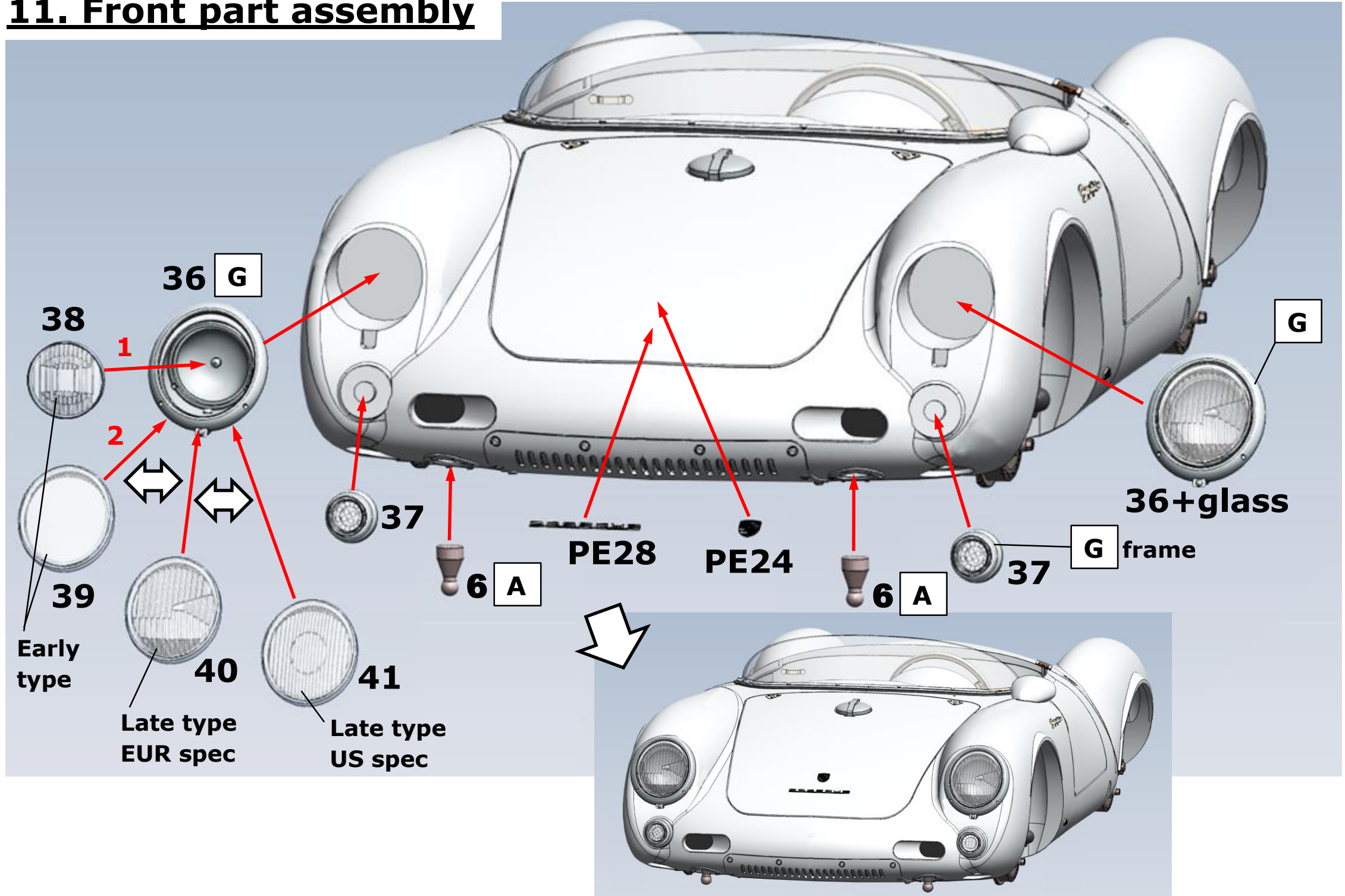

# 12. Rear part assembly

